

Installation, Operation and Maintenance

ULTRA-QUIET V SERIES Wallmount Air Conditioners



TABLE OF CONTENTS

Introduction	2
Operating & Maintenance Instructions	3
INSTALLATION	
A. Codes	4
B. Unit Site Location	4
C. Unit Preparation	4
D. Ductwork	4
E. Filters	4
F. Electrical Power	4
G. Breaker/Disconnect Assembly	4
H. Electrical Hook-up	5
I. Low Voltage Wiring	5
J. Unit Installation	5
K. Condensate Drain	5
L. Electrical Heat Installation	5
Exploded Parts Drawings	6-7
Parts List	8-11
Wiring Specifications	12-13
Wiring Diagrams	14-16
Unit Dimensions	17

CONGRATULATIONS

You have made a major investment in a fine piece of equipment. Keep your investment sound by reading these instructions before installing this unit. This will ensure that the full potential of this equipment is achieved. It will also be helpful in avoiding any needless service costs or operational problems. Included in these instructions are safety rules, installation, maintenance, and operation instructions.

Your equipment is covered by a LIMITED WARRANTY against defects in material and workmanship. Make sure that your installing dealer or contractor has returned the factory portions of the LIMITED WARRANTY CARD with the information properly entered to confirm the date of installation. Failure to return the warranty card could result in the warranty period beginning at the date of manufacture, instead of the date of installation.

Only the highest quality components were used in the construction of your unit. With proper maintenance, your system should provide years of economical, trouble-free service.

This is a vertical, wallmount unit designed for many different applications in both residential and commercial settings. It is self-contained and arrives completely assembled, factory-charged and wired. The unit is 100% run-tested at the factory to ensure proper operation. Your unit is supplied with high-quality copper tubing and enhanced aluminum-finned coils for high heat transfer efficiency and long life. The unit cabinet is constructed of G-90 galvanized steel. All exterior surfaces are finished with a baked-on polyester coating. This will provide excellent corrosion protection in most applications. However, if the unit is installed in an area with a corrosive atmosphere, such as near an industrial plant or on the seacoast, additional coating should be considered to extend the life of the coils and cabinet.

 **DANGER: BEFORE PERFORMING ANY WORK ON THIS EQUIPMENT, POWER SUPPLY MUST BE TURNED OFF AT THE HOUSEHOLD SERVICE BOX TO AVOID THE POSSIBILITY OF SHOCK, INJURY, DEATH OR DAMAGE TO EQUIPMENT.**

INSPECTION AND UNPACKING

A thorough inspection of the shipping container should be made immediately upon receiving your unit. Look for any punctures or openings. If it appears as if damage has occurred, it should be noted on the freight bill before signing. The delivering carrier should be contacted immediately to inspect damage, and no installation work should begin until this inspection is completed.

NOTES TO INSTALLER

The words "SHALL" and "MUST" indicate a requirement which is essential to satisfactory and safe product performance. The words "SHOULD" and "MAY" indicate a recommendation or advice which is not essential and not required but which may be useful or helpful.

The instructions are for the use of qualified individuals specially trained and experienced in the installation of this type equipment and related system components.

Installation and service personnel are required by some locales to be licensed. Persons not qualified SHALL NOT install this equipment nor interpret these instructions.

NOTICE: This Installation, Operation and Maintenance Manual is provided to ensure the proper installation and most satisfactory performance of your equipment. The instructions contained herein SHALL NOT be deemed to extend, modify, alter or expand any of the representations contained in the LIMITED WARRANTY.

SAFETY RULES



WARNING: FAILURE TO FOLLOW THESE RULES AND INSTRUCTIONS COULD CAUSE A MALFUNCTION OR DESTRUCTION OF THE EQUIPMENT WHICH COULD RESULT IN PROPERTY DAMAGE, SERIOUS BODILY INJURY, OR DEATH.

1. Installation and repair **MUST** be done by a qualified person. The equipment should be inspected before use and at least once annually by a professional service person.
2. **AVOID ELECTRICAL SHOCK!** Turn power OFF when servicing. There may be more than one disconnect switch to de-energize unit.
3. Close cover(s) before returning breaker(s) to "ON" position.
4. Please observe good safety practices by wearing personal protective equipment such as gloves and safety glasses to avoid injury.
5. Installation **MUST** conform to local codes. In the absence of local codes, refer to the National Electrical Code (NEC), ANS/NFPA No. 70-1993 and recommendations made by the National Board of Fire Underwriters.

In our continuing effort to improve our product, specifications may change without notice. If there are any questions, please see the contact information on the last page of this manual.

In all cases, the equipment **MUST** be installed in accordance with the installation instructions described in this manual.



WARNING: IMPROPER INSTALLATION MAY DAMAGE EQUIPMENT, CAN CREATE A HAZARD, AND WILL VOID THE WARRANTY.

OPERATING INSTRUCTIONS

If heating and cooling functions are controlled by separate thermostats, turn the furnace thermostat to the "OFF" position during the cooling season to prevent simultaneous operation of the heating and cooling systems. Reverse the procedure during the heating season.

If the same thermostat controls both heating and cooling functions, set the thermostat to either HEAT or COOL as desired.

Set the desired temperature on your thermostat dial and set the fan switch to "ON" (for continuous air circulation) or to "AUTOMATIC" (for air circulation only when the air conditioning system is operating). If you desire to vary the thermostat temperature setting during the day for energy conservation (for

example, while you are at work) do not vary the setting more than 5°F from your normal temperature setting. Changing the temperature more than 5°F or turning the thermostat off for periods less than 12 hours can actually cost you more in energy consumption than keeping the temperature constant. You should also consider indoor plants and pets when varying the temperature from the normal comfort level.

IMPORTANT: Wait at least three (3) minutes after turning the air conditioner off before trying to restart. If an attempt is made to start the compressor before the refrigerant pressures are equalized, the compressor motor may trip on its overload. An additional waiting period will be required before restarting.

MAINTENANCE

1. Always install and keep filters clean. Check filters every 10 days to 2 weeks. Clean or replace if necessary. The factory-installed filter is located behind the center front access panel.

TO CHANGE SYSTEM FILTER:

- A. Turn the power to the unit off at the unit disconnect. The disconnect is located on the front of the V Series unit behind a small access door.
- B. Remove the front center access door from the unit.
- C. Remove and replace the filters with the type and size indicated in the table below.
- D. Replace the access door and turn on the power to the unit.

NOTE: If your system has a filter grille installed in the return air opening, the unit filter should have been discarded during installation.

UNIT MODEL	QTY.	FILTER SIZE	TYPE
V24, 30, 36	1	16 x 25 x 1 (standard)	Disposable
V24, 30, 36	1	16 x 25 x 2 (optional)	Disposable
V48, 60	1	20 x 30 x 1 (standard)	Disposable
V48, 60	1	20 x 30 x 2 (optional)	Disposable

The filter installed into the return air grille assembly should be replaced with the same size and type provided with the grille.

If your system is equipped with a fresh air intake, the filter for the fresh air assembly is accessed through the front center panel. The filter is a permanent washable type.



WARNING: SERIOUS INJURY MAY RESULT IF WATER SPRAY IS DIRECTED TOWARD LIVE ELECTRICAL CONNECTIONS OR POWER SOURCES.

TO CLEAN FRESH AIR INTAKE FILTER:

- A. Follow steps A and B at left "TO CHANGE SYSTEM FILTER".
 - B. Gently pull out the filter from the bottom.
 - C. Wash the filter with water.
 - D. Reinstall the filter, by sliding it into the retaining rail.
 - E. Replace the access door and turn the power on to the unit.
2. Keep the outdoor coil clean. Wash it down with a garden hose if necessary. **BE SURE THE UNIT DISCONNECT IS IN THE "OFF" POSITION AND THAT ALL ELECTRICAL POWER TO THE UNIT IS TURNED OFF BEFORE CLEANING THE SYSTEM.**
Remove any loose grass, leaves, papers, etc., from the area around the condenser coil. These could reduce the air supply through the coil and reduce the amount of cooling capacity.
 3. Since the air conditioner is located outdoors, it is exposed to all weather elements. Treat it with a good automobile paste wax twice a year (in the spring and fall).

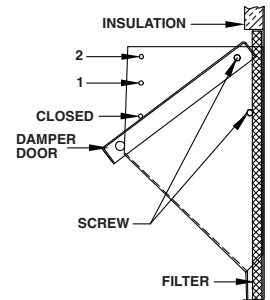

Check with your contractor if you have any questions regarding the maintenance or operation of your unit.

INSTALLATION

A. CODES

The installer SHALL comply with all local, state, and federal codes and/or regulations pertaining to this type of equipment and its installation. Such codes and/or regulations should take precedence over any recommendations contained herein in lieu of local codes. Installations SHALL be made in accordance with the National Electrical Code, local codes, and recommendations made by the National Board of Fire Underwriters.

B. UNIT SITE LOCATION

1. To eliminate noise from being transmitted into noise-sensitive areas, the unit should **NOT** be installed on walls adjoining bedrooms, sleeping quarters, or adjacent to windows.
2. Locating the unit as close as possible to the main duct system or area to be conditioned, will prevent lengthy duct runs and unnecessary thermal and air-pressure losses.
3. The clearance to combustibles is 0" on all sides, and 1/4" for the first three (3) feet of supply duct.
4. The condenser air inlets (left, right and bottom inlets) SHALL be located at least 8" away from walls or other obstructions for unrestricted airflow.
5. The condenser air outlet should be located at least 6' away from any obstructions to prevent recirculation of condenser air.
6. Service clearance is 28" from the electrical box access panel located on the front of the unit and 28" from the center, upper, and lower front access panels.
7. The wall selected for unit installation MUST be able to or be made to safely support the weight of the unit.
8. Do **NOT** locate where heat, lint or exhaust fumes will be discharged on the unit (as from dryer vents).

C. UNIT PREPARATION

1. The V Series model units have top rain flashing built onto the unit. The bottom-mounting flange for all models is shipped separately and in place. (Refer to "Section J. Unit Installation" for the recommended use of the bottom flange.)
2. Electrical entrances are located on the right side, left side, and back of all V Series units. Refer to "Section H. Electrical Hook-up" for details.
3. Return and supply air collars and air gaskets are factory installed.
4. The supply and return air ducts should be checked to be sure they:
 - a. Match the openings on the unit to be installed.
 - b. Have the same distance between them vertically as the openings on the unit to be installed.
5. If the factory-installed filter is used on your installation, access to the filter is made through the center panel on the front of the unit. **IF A REMOTE FILTER IS USED, SUCH AS A FILTER GRILLE, THE FACTORY-INSTALLED FILTER MUST BE REMOVED AND DISCARDED.**

D. DUCTWORK

1. Properly-sized duct systems are critical for satisfactory operation of any air conditioning system. All ductwork MUST be correctly sized for the design air flow requirement of the equipment.
2. The recommended operation duct static is to deduct 0.07" W.C. for any size of heater 5 kW to 20 kW on factory- or field-installed heaters.
3. Ductwork routed through wall cavities, as well as any duct not in conditioned space, MUST be insulated. Supply ducting routed through exterior walls MUST be insulated with 1" insulation to the back of the unit.
4. Supply and return air ducts should be flush with the exterior wall and sized to fit over the unit duct collars in order to compress the collar air gasket.
5. If supply duct is flashed to the exterior of a building constructed with combustible material, the flashing MUST be insulated in order to maintain the required clearances to combustible materials. Required clearance is 1/4" for the first three (3) feet of supply duct.

E. FILTERS

1. One-inch disposable filters are supplied standard in each unit. Two-inch disposable filters can also be used and are available as an option. The filter rack is adjustable to accommodate 2" filters. The filter rack on this series is adapted by bending the retaining brackets. Refer to the Maintenance section on page 3 for the procedures for changing the filters.
2. If a filter grille is used in the installation, the filter should be properly sized to allow a maximum velocity of 400 FPM. **THE FACTORY-INSTALLED FILTER MUST BE REMOVED.**

F. ELECTRICAL POWER

The installer MUST check available power to make certain it matches the unit nameplate rating and that constant voltage can be maintained to the unit. Unsatisfactory and unsafe performance could otherwise result. The local power company should be contacted about questions concerning power supply.

G. BREAKER/DISCONNECT ASSEMBLY

These units are standard equipped from the factory with a unit disconnect. This is in the form of a circuit breaker (230V models) or a disconnect (460V models). If an optional electric heat kit is to be installed, follow the instructions included with the heater assembly. See Figure 1 for reference.

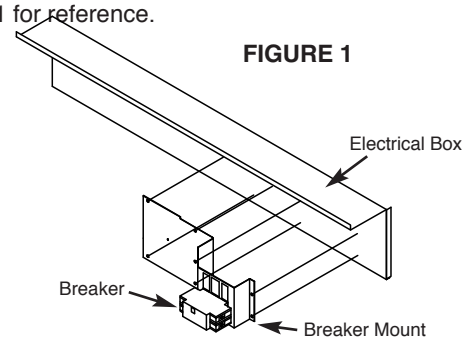



WARNING: ELECTRICAL EQUIPMENT SHOULD BE INSTALLED BY A QUALIFIED, LICENSED ELECTRICIAN. IMPROPER ELECTRICAL HOOK-UP MAY DAMAGE EQUIPMENT, CAN CREATE A HAZARD AND WILL VOID WARRANTY.

H. ELECTRICAL HOOK-UP

The line voltage electrical service can be routed through the right side panel, the right side of the back panel, or left side panel. Each area is supplied with two line voltage knock-outs (1/2" – 3/4" and 1" – 1 1/4"). Low voltage wiring can be routed through the right side panel.

NOTE: When routing line voltage through the return air compartment, conduit **MUST** be used (even though this is a dry area) to comply with the NEC code. A 1 1/4" PVC conduit is supplied for this application. Refer to the tables on pages 12 – 13 for minimum wire size and maximum breaker size. All wire sizes listed under the dual-feed circuit column are based on no more than three (3) conductors in the same conduit. If two circuits or more than three (3) conductors are to be routed in the same conduit, the ampacity of the wire size listed **MUST** be derated. Refer to Article 310 of the NEC code for adjustment factors. Be sure to install a ground wire of the proper size to the unit's equipment ground lug.

I. LOW VOLTAGE WIRING

230 volt, 1- and 3-phase units are equipped with dual-primary voltage transformers for 208/240 volt operation. These models are factory wired to the 240 volt tap. For 208 volt operation connect the factory-installed black wires from the 240 volt tap to the 208 volt tap. The acceptable voltage range of the tap is as follows.

Tap	Voltage Range
240 Volt	253 - 216
208 Volt	220 - 187

Five (5) conductor thermostat wires should be run from the thermostat location to the unit. Thermostat wire should be sized as shown on the table below.

Refer to wiring diagrams on pages 14 – 16 for connection details.

Wire Gauge	Maximum Length
20	45'
18	60'
16	100'
14	160'
12	250'

STAGING OF ELECTRIC HEAT

All V Series units with electric heat assemblies above 10 kW may be wired for single- or two-stage heat. These models come factory wired for single-stage operation. For two-stage operation, remove the jumper bar from between the W2 and E terminal. Wire the first-stage heat to terminal W2. Wire the second-stage heat to terminal E.

J. UNIT INSTALLATION

V SERIES UNITS ARE FOR USE IN SINGLE-STORY BUILDINGS ONLY

1. As previously stated, the wall that the unit is to be installed onto **MUST** be strong enough to support the unit under the condition for which it will be used. For example, a unit to be installed on a building that is intended to be transported will require more wall strength than a unit installed at a permanent site. Existing walls may need additional reinforcement. **NEVER RELY ON EXTERIOR SIDING OR PLYWOOD TO SUPPORT THE UNIT.** Figure 2 below represents a typical installation of a single-story stud wall at a permanent site. Since building materials and techniques vary with regions and intended use, a building contractor and/or local building code official **MUST** be consulted for suitable construction methods.
2. Locate and attach the lower mounting bracket in the desired location on the building.
3. Apply a suitable caulk across the entire length of the top rain flashing and side mounting flanges.
4. Remove the flanges on both ends of the pallet and slide the unit approximately 2" off the rear of pallet. Lift unit gently into location with fork truck, taking care to align unit with lower mounting bracket.
5. While allowing a small portion of weight on the lower bracket, push the unit against the wall and fasten appropriately.

FIGURE 2

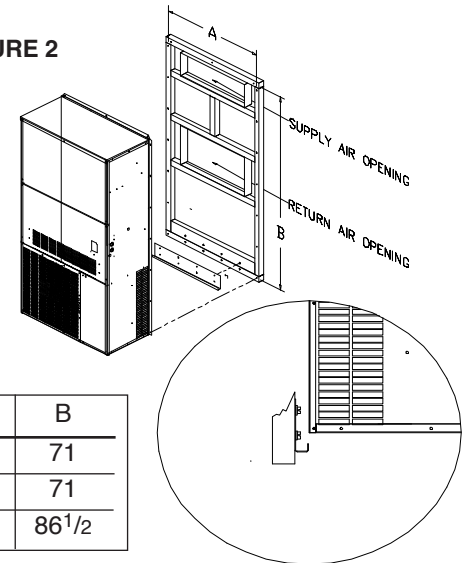

Unit Model	A	B
V24	35	71
V30/36	39	71
V48/60	42	86 1/2

MOUNTING FLANGE BOLT PATTERN DIMENSIONS

K. CONDENSATE DRAIN

A 3/4" drain hose is located on the bottom side of the unit. The drain may be extended for condensate removal to comply with local codes (use fitting size or larger). Install a condensate trap on this line.

L. ELECTRICAL HEAT INSTALLATION

Electric heat is an option on V Series units and can be field-installed on either single- or three-phase models.

Refer to the individual installation instructions for installing heater kits.

EXPLODED PARTS DRAWING — V24 / V30 / V36

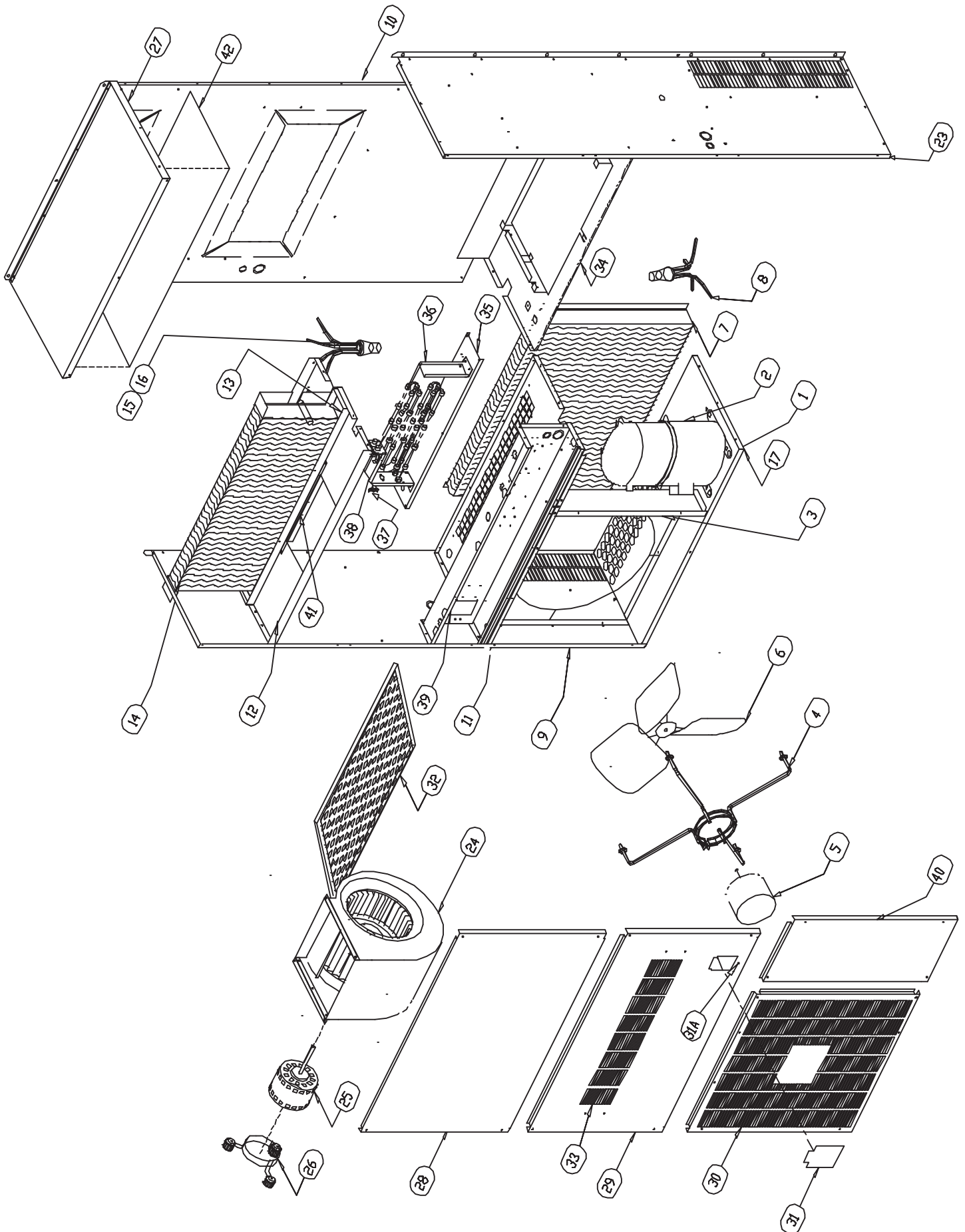

EXPLODED PARTS DRAWING — V48 / V60

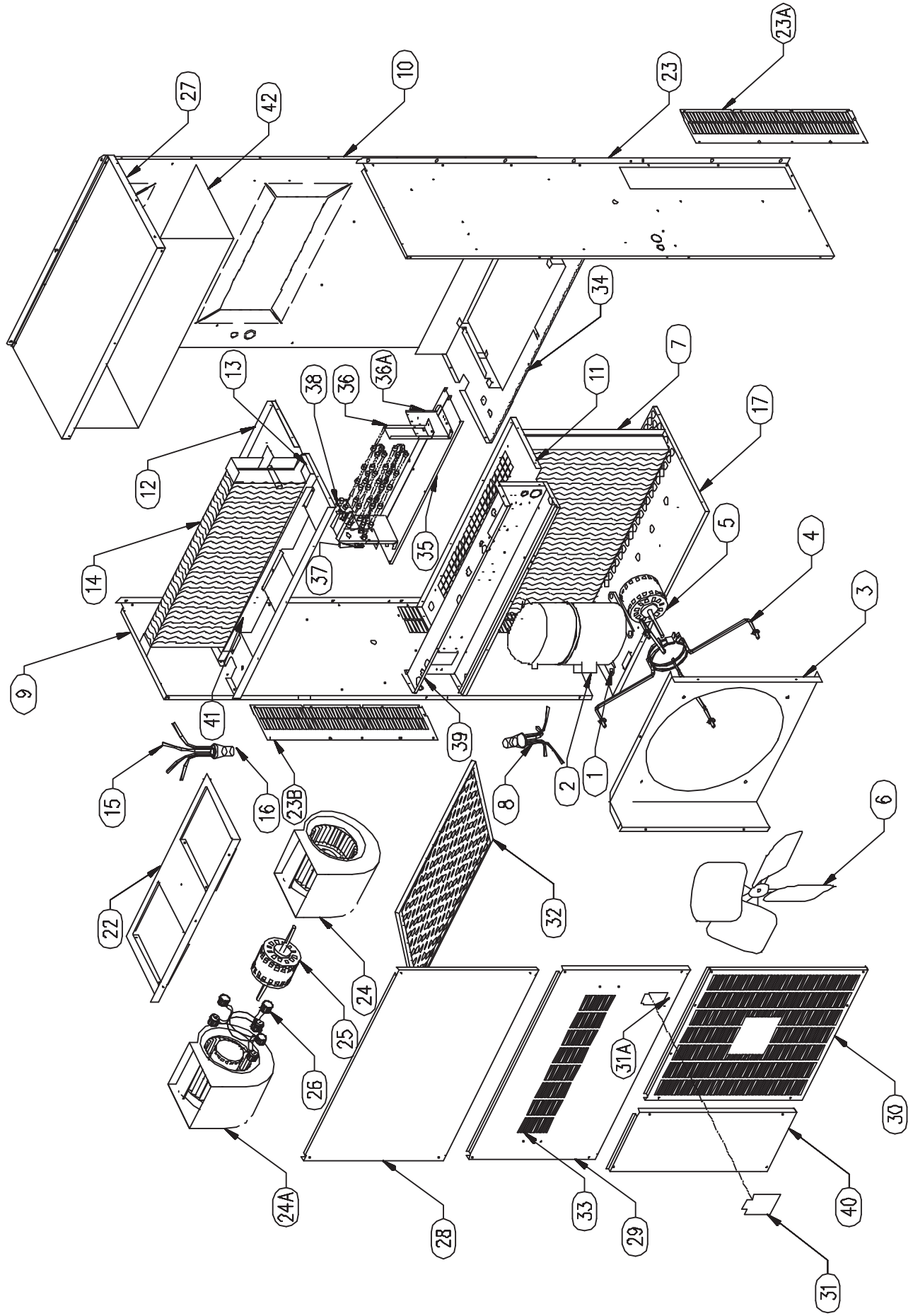

REPLACEABLE PARTS LIST FOR V SERIES WALLMOUNT A/C UNITS

PART #	DESCRIPTION	V18	V24A-1	V24A-3	V24A-4	V30D-1	V30A-3	V30A-4	V30D-1	V30A-3	V30A-4	V38D-1	V38A-3	V38A-4	V42A-1	V42A-3	V42A-4	V48B-1	V48B-3	V48B-4	V60B-1	V60B-3	V60B-4		
1	COMP-MTGA COMP MTG ASSEMBLY RECIP. V18-42	X																							
1	COMP-MTGB COMP MTG GROMMET SCROLL V48-60																								
2	054005 COMPRESSOR CR16KF-PFV	X																							
2	054040 COMPRESSOR CR22KF-PFV		X																						
2	194200020001 COMPRESSOR AWF5522EXN					X																			
2	054016D COMPRESSOR AWF5528EXN																								
2	054036D COMPRESSOR AWF5533EXN70																								
2	054016 COMPRESSOR CR28KF-PFV																								
2	054036 COMPRESSOR CR34KF-PFV																								
2	054024 COMPRESSOR CR38K6-PFV																								
2	053253 COMPRESSOR ZR47KC-PFV																								
2	053256 COMPRESSOR ZR57KC-PFV																								
2	054014 COMPRESSOR CR22K6-TF5 230V 3PH			X																					
2	162600070002 COMPRESSOR CR22K6-TFD 460V 3PH				X																				
2	054048 COMPRESSOR CR28K6-TF5 230V 3PH						X																		
2	054054 COMPRESSOR CR28K6-TFD 460V 3PH							X																	
2	162600070004 COMPRESSOR CR35K6-TF5 230V 3PH													X											
2	162600070006 COMPRESSOR CR35K6-TFD 460V 3PH															X									
2	054052 COMPRESSOR CR38K6-TF5 230V 3PH																								
2	054028 COMPRESSOR CR38K6-TFD 460V 3PH																								
2	053249 COMPRESSOR ZR47KC-TF5 230V 3PH																								
2	053252 COMPRESSOR ZR47KC-TFD 460V 3PH																								
2	052357 COMPRESSOR ZR57KC-TF5 230V 3PH																								
2	053255 COMPRESSOR ZR57KC-TFD 460V 3PH																								
3	2021-5008 FAN SHROUD V18-24	X	X	X	X																			X	
3	2022-5008 FAN SHROUD V30-36					X	X	X	X	X	X	X	X	X	X	X	X	X	X	X	X	X	X	X	
3	2023-5008 FAN SHROUD V42-60																								
4	259108 MOTOR MOUNT CONDENSER FAN																								
4	259109 MOTOR MOUNT CONDENSER FAN																								
5	0250-0025 MOTOR CONDENSER 230V 1/5 HP																								
5	351145 MOTOR CONDENSER 230V 1/2 HP																								
5	359100 MOTOR CONDENSER 460V 1/4 HP																								
5	351146 MOTOR CONDENSER 460V 1/2 HP																								
6	0550-0009 FAN BLADE 20" V18-36	X	X	X	X	X	X	X	X	X	X	X	X	X	X	X	X	X	X	X	X	X	X	X	
6	259114 FAN BLADE 22" V42-60																								
7	194500300001 COIL, CONDENSER V18-24	X	X	X	X	X	X	X	X	X	X	X	X	X	X	X	X	X	X	X	X	X	X	X	
7	194500302001 COIL, CONDENSER V30-36																								
7	194500298001 COIL, CONDENSER V42																								
7	194500299001 COIL, CONDENSER V48-60																								
8	550505-S FLOW RATER 3 CKT	X	X	X	X	X	X	X	X	X	X	X	X	X	X	X	X	X	X	X	X	X	X	X	
8	550510-S FLOW RATER 4 CKT																								
8	550520-S FLOW RATER 8 CKT																								
9	2022-5000 ASSEMBLY LEFT SIDE PANEL V18-36	X	X	X	X	X	X	X	X	X	X	X	X	X	X	X	X	X	X	X	X	X	X	X	
9	2023-5000 ASSEMBLY LEFT SIDE PANEL V42-60																								
10	2021-5012 ASSEMBLY REAR PANEL V18-24	X	X	X	X	X	X	X	X	X	X	X	X	X	X	X	X	X	X	X	X	X	X	X	
10	2022-5012 ASSEMBLY REAR PANEL V30-36																								
10	2023-5012 ASSEMBLY REAR PANEL V42-60																								
11	2021-5003 ASSEMBLY DIVIDER DECK V18-24	X	X	X	X	X	X	X	X	X	X	X	X	X	X	X	X	X	X	X	X	X	X	X	
11	2022-5003 ASSEMBLY DIVIDER DECK V30-36																								
11	2023-5003 ASSEMBLY DIVIDER DECK V42-60																								
12	2021-5005 ASSEMBLY BLOWER PAN V18-24	X	X	X	X	X	X	X	X	X	X	X	X	X	X	X	X	X	X	X	X	X	X	X	
12	2022-5005 ASSEMBLY BLOWER PAN V30-36																								
12	2023-5005 ASSEMBLY BLOWER PAN V42-60																								
13	2021-0006P ASSEMBLY DRAIN PAN V18-24	X	X	X	X	X	X	X	X	X	X	X	X	X	X	X	X	X	X	X	X	X	X	X	
13	2022-0006P ASSEMBLY DRAIN PAN V30-36																								
13	2023-5006 ASSEMBLY DRAIN PAN V42-60																								
14	194500301001 EVAPORATOR COIL V18-24	X	X	X	X	X	X	X	X	X	X	X	X	X	X	X	X	X	X	X	X	X	X	X	

REPLACEABLE PARTS LIST FOR V SERIES WALLMOUNT A/C UNITS

PART #	DESCRIPTION	V18	V24A-1	V24A-3	V24A-4	V30D-1	V30A-3	V30A-4	V30D-1	V30A-3	V30A-4	V30D-1	V30A-3	V30A-4	V36A-3	V36A-4	V42A-1	V42A-3	V42A-4	V48B-1	V48B-3	V48B-4	V60B-1	V60B-3	V60B-4		
14	194500303001	EVAPORATOR COIL V30-36							X	X	X	X	X	X	X	X	X	X	X	X	X	X	X	X	X		
14	194500290001	EVAPORATOR COIL V42																									
14	194500291001	EVAPORATOR COIL V48-60																									
15	550510-S	FLOW RATER 4 CKT	X	X	X	X	X	X	X	X	X	X	X	X	X	X	X	X	X	X	X	X	X	X	X	X	
15	550520-S	FLOW RATER 8 CKT																									
16	550534	RESTRICTOR .057	X																								
16	550531	RESTRICTOR .065		X	X	X	X	X	X	X	X	X	X	X	X	X	X	X	X	X	X	X	X	X	X	X	
16	550537	RESTRICTOR .068																									
16	550540	RESTRICTOR .074																									
16	550547	RESTRICTOR .080																									
16	550546	RESTRICTOR .088																									
16	550549	RESTRICTOR .098																									
17	2021-5002	BASE PAN ASSEMBLY V18-24	X	X	X	X	X	X	X	X	X	X	X	X	X	X	X	X	X	X	X	X	X	X	X	X	
17	2022-5002	BASE PAN ASSEMBLY V30-36																									
17	2023-5002H	BASE PAN ASSEMBLY V42-60																									
22	2021-5018	BLOWER MNTG TRAY V18-24	X	X	X	X	X	X	X	X	X	X	X	X	X	X	X	X	X	X	X	X	X	X	X	X	
22	2022-5018	BLOWER MNTG TRAY V30-36																									
22	2023-5018-4	BLOWER MNTG TRAY V42-48																									
22	2023-5018-5	BLOWER MNTG TRAY V60																									
23	2022-5001	ASSEMBLY RIGHT SIDE V18-36	X	X	X	X	X	X	X	X	X	X	X	X	X	X	X	X	X	X	X	X	X	X	X	X	
23	2023-5001	ASSEMBLY RIGHT SIDE V42-60																									
23a	2023-5088	GRILL INLET RIGHT SIDE V42-60																									
23b	2023-5089	GRILL INLET LEFT SIDE V42-60																									
24	194700050002	BLOWER 9-7R DD 18, 24, 42 & 48 CW RIGHT	X	X	X	X	X	X	X	X	X	X	X	X	X	X	X	X	X	X	X	X	X	X	X	X	
24	194700050004	BLOWER 10-7R DD 60 CW RIGHT																									
24	0500-0010	BLOWER 10-10 DD 30 & 36																									
24a	194700050001	BLOWER 9-7L DD 42 & 48 CCW LEFT																									
24a	194700050003	BLOWER 10-7L DD 60 CCW LEFT																									
25	0200-0028	MOTOR BLOWER 1/6 HP 230V	X	X	X	X	X	X	X	X	X	X	X	X	X	X	X	X	X	X	X	X	X	X	X	X	
25	0200-0027	MOTOR BLOWER 1/3 HP 230V																									
25	351500	MOTOR BLOWER 1/2 HP double shaft 230V																									
25	351424	MOTOR BLOWER 3/4 HP double shaft 230V																									
25	359101	MOTOR BLOWER 1/3 HP 460V																									
25	351440A	MOTOR BLOWER 1/2 HP double shaft 460V																									
25	351426	MOTOR BLOWER 3/4 HP double shaft 460V																									
26	BLWR-MTG2	MOTOR MOUNT INDOOR ASSY V18-24	X	X	X	X	X	X	X	X	X	X	X	X	X	X	X	X	X	X	X	X	X	X	X	X	
26	BLWR-MTG3	MOTOR MOUNT INDOOR ASSY V30-36																									
26	BLWR-MTG5	MOTOR MOUNT INDOOR ASSY V42-60																									
27	2021-5007	TOP V18-24	X	X	X	X	X	X	X	X	X	X	X	X	X	X	X	X	X	X	X	X	X	X	X	X	
27	2022-5007	TOP V30-36																									
27	2023-5007	TOP V42-60																									
28	2021-5010	TOP FRONT PANEL V18-24	X	X	X	X	X	X	X	X	X	X	X	X	X	X	X	X	X	X	X	X	X	X	X	X	
28	2022-5010	TOP FRONT PANEL V30-36																									
28	2023-5010	TOP FRONT PANEL V42-60																									
29	2021-5011	MIDDLE FRONT PANEL (NO FRESH AIR) V18-24	X	X	X	X	X	X	X	X	X	X	X	X	X	X	X	X	X	X	X	X	X	X	X	X	
29	2021-5011E	MIDDLE FRONT PANEL (ECONOMIZER F/A) V18-24	X	X	X	X	X	X	X	X	X	X	X	X	X	X	X	X	X	X	X	X	X	X	X	X	
29	2021-5011F	MIDDLE FRONT PANEL (BAROMETRIC F/A) V18-24	X	X	X	X	X	X	X	X	X	X	X	X	X	X	X	X	X	X	X	X	X	X	X	X	
29	2022-5011	MIDDLE FRONT PANEL (NO FRESH AIR) V30-36																									
29	2022-5011E	MIDDLE FRONT PANEL (ECONOMIZER F/A) V30-36																									
29	2022-5011F	MIDDLE FRONT PANEL (NO FRESH AIR) V42-60																									
29	2023-5011E	MIDDLE FRONT PANEL (BAROMETRIC F/A) V42-60																									
29	2023-5011F	MIDDLE FRONT PANEL (ECONOMIZER) V42-60																									
29	2023-5011F	MIDDLE FRONT PANEL (BAROMETRIC F/A) V42-60																									
30	2021-5014	LOWER CONDENSER PANEL V18-24	X	X	X	X	X	X	X	X	X	X	X	X	X	X	X	X	X	X	X	X	X	X	X	X	
30	2022-5014	LOWER CONDENSER PANEL V30-36																									
30	2023-5014	LOWER CONDENSER PANEL V42-60																									
31	2022-5062	DISCONNECT ACCESS DOOR V18-60	X	X	X	X	X	X	X	X	X	X	X	X	X	X	X	X	X	X	X	X	X	X	X	X	

REPLACEABLE PARTS LIST FOR V SERIES WALLMOUNT A/C UNITS

PART #	DESCRIPTION	OPT I O N A L										O P T I O N A L									
		V18	V24A-1	V24A-3	V24A-4	V30A-1	V30A-3	V30A-4	V36A-1	V36A-3	V36A-4	V42A-1	V42A-3	V42A-4	V48B-1	V48B-3	V48B-4	V60B-1	V60B-3	V60B-4	
31a	BREAKER DOOR LATCH (CAMLOCK ASSY) V18-60	X	X	X	X	X	X	X	X	X	X	X	X	X	X	X	X	X	X	X	
32	AIR FILTER DISPOSABLE 16 x 25 x 1 V18-36	X	X	X	X	X	X	X	X	X	X	X	X	X	X	X	X	X	X	X	
32	AIR FILTER DISPOSABLE 16 x 25 x 1 V18-36	X	X	X	X	X	X	X	X	X	X	X	X	X	X	X	X	X	X	X	
32	AIR FILTER DISPOSABLE 16 x 25 x 2 V18-36																				
32	AIR FILTER DISPOSABLE 20 x 30 x 1 V42-60																				
32	AIR FILTER DISPOSABLE 20 x 30 x 2 V42-60																				
32	AIR FILTER DISPOSABLE 20 x 30 x 2 V42-60																				
33	FRESH AIR FILTER 5 x 30 x 0.25 WASHABLE V18-60	X	X	X	X	X	X	X	X	X	X	X	X	X	X	X	X	X	X	X	
33	FRESH AIR FILTER 5.25 x 29 x 0.25 WASHABLE V18-60	X	X	X	X	X	X	X	X	X	X	X	X	X	X	X	X	X	X	X	
34	FILTER RACK V18-24	X	X	X	X	X	X	X	X	X	X	X	X	X	X	X	X	X	X	X	
34	FILTER RACK V30-36																				
34	FILTER RACK V42-60																				
35	HEATER MOUNTING PLATE V18-36	X	X	X	X	X	X	X	X	X	X	X	X	X	X	X	X	X	X	X	
35	HEATER MOUNTING PLATE V42-60																				
36	HEATER ELECTRIC 3 kW	X	X	X	X	X	X	X	X	X	X	X	X	X	X	X	X	X	X	X	
36	0430-0089																				
36	** HEATER ELECTRIC 5 kW	X	X	X	X	X	X	X	X	X	X	X	X	X	X	X	X	X	X	X	
36	0430-0074																				
36	** HEATER ELECTRIC 10 kW	X	X	X	X	X	X	X	X	X	X	X	X	X	X	X	X	X	X	X	
36	0430-0072																				
36	HEATER ELECTRIC 7 kW	X	X	X	X	X	X	X	X	X	X	X	X	X	X	X	X	X	X	X	
36	458008																				
36	HEATER ELECTRIC 3 kW 230V 3 Phase																				
36	458009																				
36	HEATER ELECTRIC 6 kW 230V 3 Phase																				
36	458010																				
36	HEATER ELECTRIC 9 kW 230V 3 Phase																				
36	458011																				
36	HEATER ELECTRIC 11 kW 230V 3 Phase																				
36	458014																				
36	HEATER ELECTRIC 3 kW 460V 3 Phase																				
36	458015																				
36	HEATER ELECTRIC 6 kW 460V 3 Phase																				
36	458016																				
36	HEATER ELECTRIC 9 kW 460V 3 Phase																				
36	458017																				
36	HEATER ELECTRIC 11 kW 460V 3 Phase																				
36	458018																				
36	HEATER ELECTRIC 15 kW 460V 3 Phase																				
37	454332 SWITCH LIMIT 245F One Shot	X	X	X	X	X	X	X	X	X	X	X	X	X	X	X	X	X	X	X	
38	454323 *SWITCH LIMIT 160-30F 240 W/Fuse	X	X	X	X	X	X	X	X	X	X	X	X	X	X	X	X	X	X	X	
39	2021-5009H BOX CONTROL V18-24																				
39	2022-5009H BOX CONTROL V30-36																				
39	2023-5009H BOX CONTROL V42-60																				
40	2021-5017 COMPRESSOR ACCESS DOOR V18-24	X	X	X	X	X	X	X	X	X	X	X	X	X	X	X	X	X	X	X	
40	2022-5017 COMPRESSOR ACCESS DOOR V30-36																				
40	2023-5017 COMPRESSOR ACCESS DOOR V42-60																				
41	2021-5020 BLOWER CUT OFF SHIELD V18-24	X	X	X	X	X	X	X	X	X	X	X	X	X	X	X	X	X	X	X	
41	2022-5020 BLOWER CUT OFF SHIELD V30-36																				
41	2023-5020-4 BLOWER CUT OFF SHIELD V42-48																				
41	2023-5020-5 BLOWER CUT OFF SHIELD V60																				

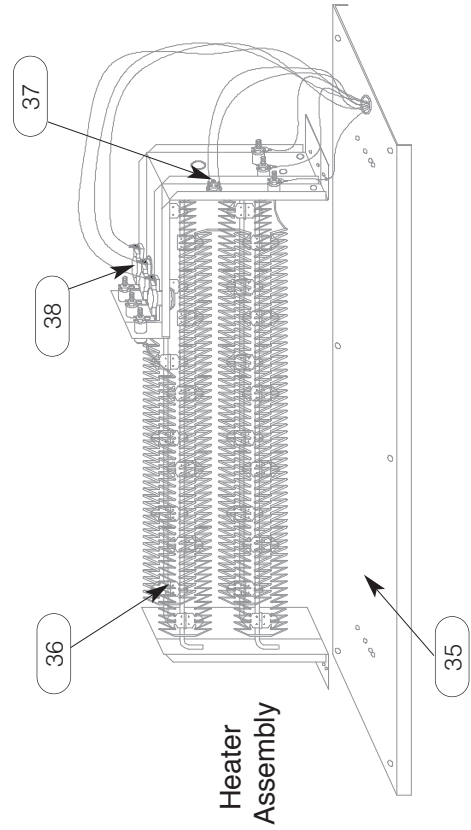

Heater Assembly

* Not interchangeable.
 ** Use both 0430-0074 and 0430-0072 for Heater Electric 15 kW 230V 1 and 3 Phase.

CONTROL BOX

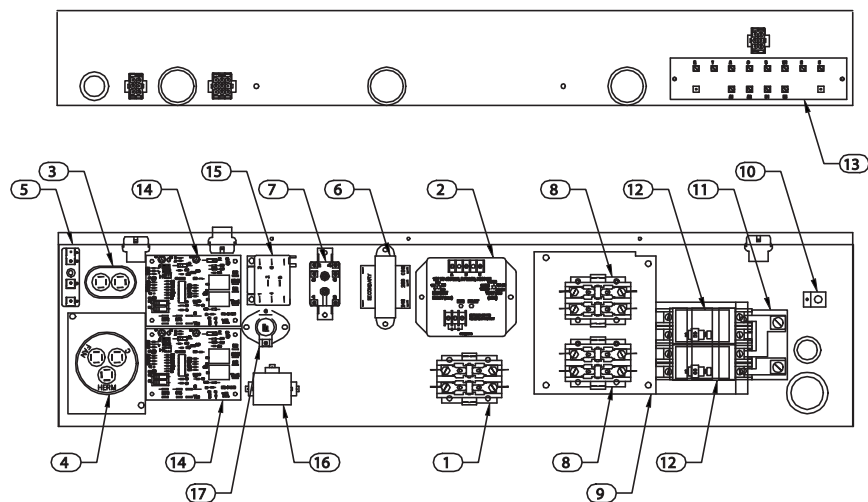

CONTROL BOX PARTS LIST

ITEM	PART	DESCRIPTION
1	453150	COMPRESSOR CONTACTOR 1 POLE 1PH 25 AMP
1	453770	COMPRESSOR CONTACTOR 2 POLE 1PH 40 AMP
1	453772	COMPRESSOR CONTACTOR 3 POLE 3PH 25 AMP
2	452842	PHASE MONITOR (3 PHASE SCROLL MODELS)
3	450205	CAPACITOR SINGLE 7.5 / 370
3	450325	CAPACITOR SINGLE 10 / 370
3	450375	CAPACITOR SINGLE 12.5 / 370
4	450360	CAPACITOR DUAL 25+ 7.5 / 370
4	450361	CAPACITOR DUAL 30+ 7.5 / 370
4	450362	CAPACITOR DUAL 35+ 7.5 / 370
4	450368	CAPACITOR DUAL 40+ 7.5 / 370
4	450364	CAPACITOR DUAL 40+ 7.5 / 440
4	450370	CAPACITOR DUAL 45+ 7.5 / 370
4	450371	CAPACITOR DUAL 50+ 7.5 / 370
4	0400-0033	CAPACITOR DUAL 50+ 10 / 440
4	0400-0045	CAPACITOR DUAL 70+ 10 / 440
5	451000	TERMINAL BLOCK (IBM)
6	454252	TRANSFORMER 208/240 V - 24V 50VA
6	040500	TRANSFORMER 480 V - 24V 50VA
7	452200	FAN RELAY SPDT (230V models)
7	452190	FAN RELAY DPDT (460V models)
8	453151	HEATER CONTACTOR 30 AMP RES
9	2022-5031	CIRCUIT BREAKER STAND (230 VOLT)
9	654600-F	DISCONNECT STAND (460 VOLT)
10	456175	LUGS-GROUND 6-14 AWG
11	451049	SINGLE FIELD CIRCUIT JUMPER
12	042004	CIRCUIT BREAKER 60 AMP 230 VOLT 1 PHASE
12	451955-KIT	DISCONNECT KIT 460 VOLT
13	0415-0028	LOW VOLTAGE TERMINAL BOARD
14	451840	OPTION BOARD
15	452190	LOW AMBIENT OFM RELAY (460V ONLY)
16	PTCR-3	START ASSIST PTCR-3 (V24, V30, V36 MODELS)
16	PTCR-5	START ASSIST PTCR-5 (V48, V60 MODELS)

ELECTRICAL DATA

[1] MODEL NO. AND ELECTRIC HEATER KW	VOLT/ PHASE	MAX. UNIT AMPS	NO. OF FIELD POWER CKTS.	SINGLE-FIELD CIRCUIT				DUAL-FIELD CIRCUIT							
				MINIMUM WIRE AMPACITY	[2] MAX OVER CURRENT PROTECTION	[3,4,5] FIELD POWER WIRE SIZE	GROUND WIRE SIZE	MIN. WIRE AMPACITY		MAX OVER CURRENT PROTECTION [2]		FIELD POWER WIRE SIZE [3], [4], [5]		GROUND WIRE SIZE	
								CKT1	CKT2	CKT1	CKT2	CKT1	CKT2	CKT1	CKT2
V24A00A1 5 10	208-230/1	13.8 22.2 43.1	1 1 1	17 28 54	25 30 60	10 10 6	10 10 10								
V30A00A1 5 10	208-230/1	19.3 23.3 44.2	1 1 1	23 29 55	30 40 60	10 10 6	10 10 10								
V36A00A1 5 10 15	208-230/1	20.6 23.3 44.2 65.0	1 1 1 1OR2	25 29 55 81	40 40 60 90	10 10 6 4	10 10 10 6	25	57	40	90	10	6	10	10
V30B00A1 5 10 15	208-230/1	19.0 23.3 44.2 65.0	1 1 1 1OR2	23 29 55 81	30 40 60 90	10 10 6 4	10 10 10 6	23	59	30	90	10	6	10	10
V36B001A 5 10 15	208-230/1	21.9 23.3 44.2 65.0	1 1 1 1OR2	26 29 55 81	40 40 60 90	10 10 6 4	10 10 10 6	26	55	40	90	10	6	10	10
V48B00A1 5 10 15	208-230/1	30.0 30/3 47.7 66.1	1 1 1 1OR2	36 36 57 83	60 60 60 90	8 8 6 4	10 10 8 6	36	57	60	60	8	6	10	10
V60B00A1 5 10 15	208-230/1	34.1 34.1 47.8 66.1	1 1 1 1OR2	41 41 57 83	60 60 60 90	8 8 6 4	10 10 8 6	41	57	60	60	8	6	10	10
V36A00A3 6 11	208-230/3	15.4 16.9 30.1	1 1 1	18 21 38	25 25 40	10 10 8	10 10 10								
V48B00A3 6 11 18	208-230/3	22.4 17.9 30.0 46.9	1 1 1 1	27 22 38 59	40 30 40 60	8 10 8 6	10 10 10 8								
V60B00A3 6 11 18	208-230/3	25.4 19.4 30.1 46.9	1 1 1 1	30 23 38 59	45 30 45 60	8 8 8 6	10 10 10 8								
V60B00A4 6 11 15	460/3	12.7 15.6 15.4 20.2	1 1 1 1	15 19 19 25	25 30 25 30	10 10 10 10	10 10 10 10								

[1] Heater data is based on 240V and 480V AC respectively.

[2] Maximum recommended size of "Time Delay" fuse or HACR circuit breaker.

[3] Power supply wire size and ground wire sizes are based on AWG. 75C rise, NEC Article 310 and table 310-16.

[4] For single power supply conductor, sized per NEC table 310-16.

[5] Power supply wire uses 75C rated COPPER CONDUCTORS ONLY.

CURRENT 07/01/03
 C - CAPACITOR
 CH - CRANKCASE HEATER
 COMP - COMPRESSOR
 CSR - COMPRESSOR STOP RELAY (OPT)
 DCR - DUAL CAPACITOR
 DFC - DEFROST CONTROL

ELECTRICAL LEGEND
 DFT - DEFROST T/STAT
 EH - ELECTRIC HEATER
 EHR - ELECTRIC HEAT RELAY
 FR - FAN RELAY
 HPS - HIGH PRESSURE SWITCH (OPT)
 HR - HEAT RELAY

IBN - INDOOR BLOWER MOTOR
 LAC - LOW AMBIENT FAN CONTROL (OPT)
 LAR - LOW AMBIENT ROOM RELAY (OPT)
 LPS - LOW PRESSURE SWITCH (OPT)
 OFM - OUTDOOR FAN MOTOR
 RVS - REVERSING VALVE SOLENOID

SC - START CAPACITOR (OPT)
 SR - START RELAY (OPT)
 TCR - THERMOSTAT RELAY (OPT)
 TDR - THERMOSTAT RELAY (OPT)
 TDR - THERMOSTAT RELAY (OPT)
 TDR - THERMOSTAT RELAY (OPT)

DRAWING APPLIES TO
 V18A00A1XXX--XX
 V24A00A1XXX--XX
 V30A00A1XXX--XX
 V36A00A1XXX--XX
 V42B00A1XXX--XX
 V48B00A1XXX--XX
 V60B00A1XXX--XX

DRAWING NO. 1120-0000-0000
 REV F
 BASIC AIR CONDITIONER SYSTEM

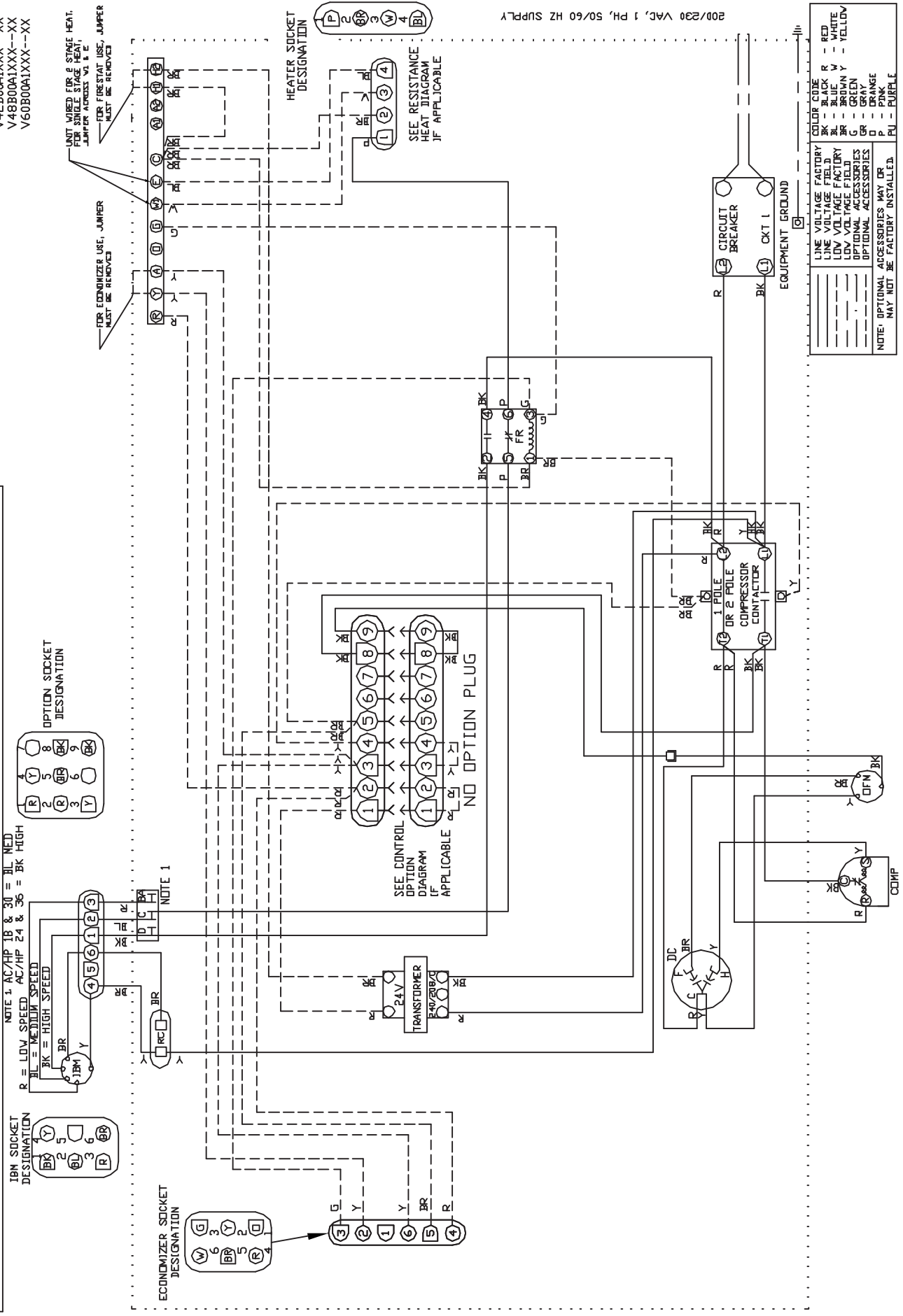

LINE VOLTAGE FACTORY	COLOR CODE
LINE VOLTAGE FIELD	BLACK R - RED
LOW VOLTAGE FIELD	BLUE Y - WHITE
OPTIONAL ACCESSORIES	BROWN Y - YELLOW
OPTIONAL ACCESSORIES	GREEN G - GREEN
OPTIONAL ACCESSORIES	GRAY GR - GRAY
OPTIONAL ACCESSORIES	ORANGE O - ORANGE
OPTIONAL ACCESSORIES	PURPLE PU - PURPLE

NOTE: OPTIONAL ACCESSORIES MAY OR MAY NOT BE FACTORY INSTALLED.

CURRENT 07/01/03
 C - CAPACITOR
 CH - CHANGING HEATER
 COMP - COMPRESSOR
 CST - COMPRESSOR STOP RELAY (OPT)
 CSR - COMPRESSOR STOP RELAY (OPT)
 IC - DUAL CAPACITOR
 JFC - DEFROST CONTROL

ELECTRICAL LEGEND
 DFY - DEFROST T/STAT
 EH - ELECTRIC HEATER
 EHL - ELECTRIC HEAT LIMIT (L-SHOT)
 ESR - ECONOMIZER SHUNT RELAY
 FR - FAN RELAY
 HPS - HIGH PRESSURE SWITCH (OPT)
 HR - HEAT RELAY

IBN - INDOOR BLOWER MOTOR
 LAC - LOW AMBIENT FAN CONTROL (OPT)
 LASR - LOW AMBIENT SHUNT RELAY (OPT)
 LC - LIMIT CONTROL CUTOFF (OPT)
 LPS - LOW PRESSURE SWITCH (OPT)
 OFM - OUTDOOR FAN MOTOR
 RVS - REVERSING VALVE SOLENOID

SC - START CAPACITOR (OPT)
 SP - START RELAY (OPT)
 TCR - TELECOM BOARD (OPT)
 TOR - TIME DELAY RELAY (OPT)
 (OPT) - OPTIONAL ACCESSORIES

DRAWING NO. 1120-0008-0000
 REV F
 BASIC AIR CONDITIONER SYSTEM

DRAWING APPLIES TO
 V2400A3XXX--XX
 V3000A3XXX--XX
 V3600A3XXX--XX
 V4200A3XXX--XX
 V4800A3XXX--XX
 V6000A3XXX--XX

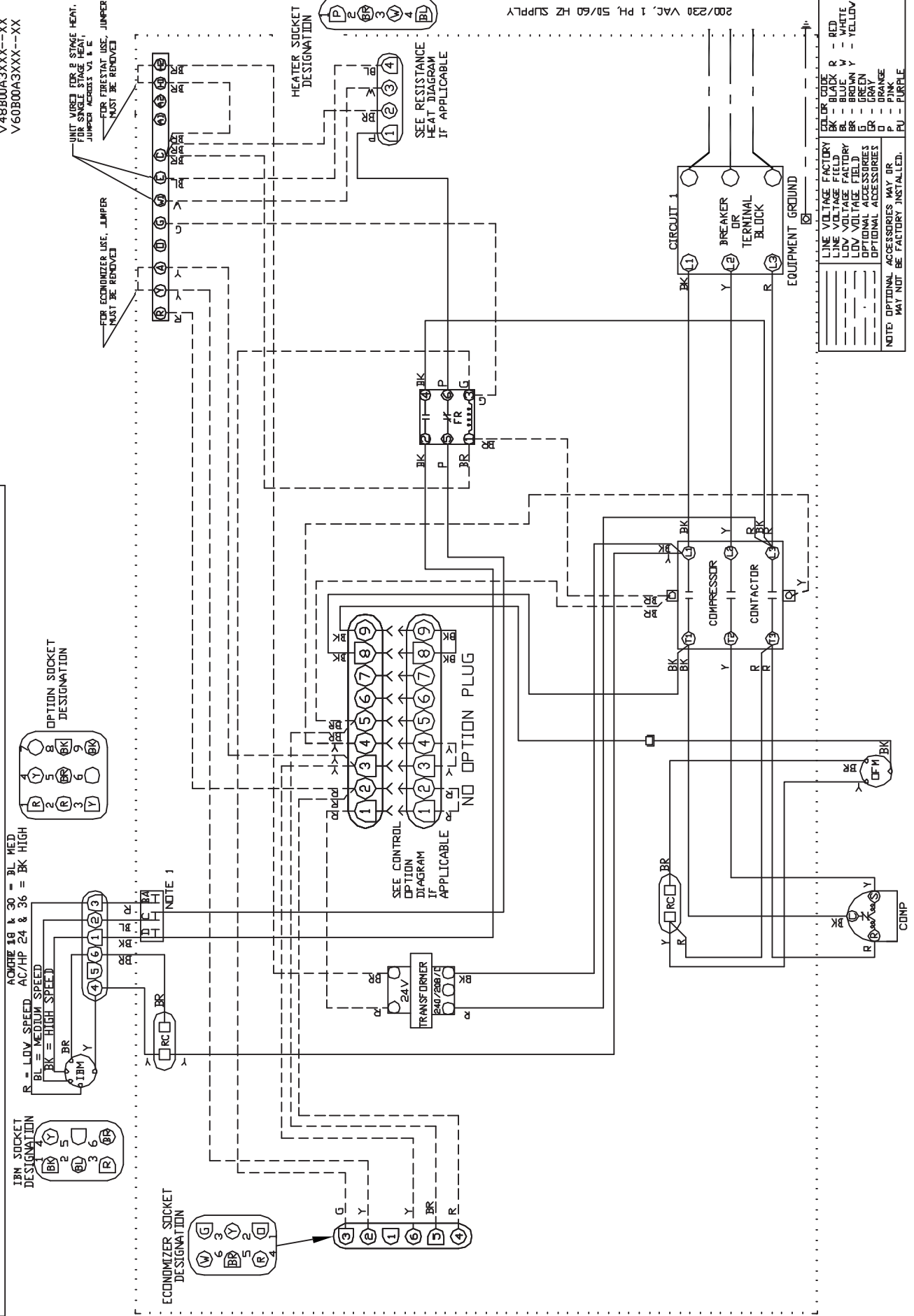

CURRENT 07/01/03
 C - CAPACITOR
 CSH - CRANKCASE HEATER
 COMP - COMPRESSOR
 CST - COMPRESSOR STOP RELAY (OPT)
 CSR - COMPRESSOR STOP RELAY (OPT)
 DC - DUAL CAPACITOR
 DFC - DEFROST CONTROL

- ELECTRICAL LEGEND
 DFT - DEFROST T-STAT
 EH - ELECTRIC HEATER
 EHL - ELECTRIC HEAT LIMIT (L SHOT)
 ESR - ECONOMIZER SHUNT RELAY
 FR - FAN RELAY
 HPS - HIGH PRESSURE SWITCH (OPT)
 HR - HEAT RELAY

IBM - INDOOR BLOWER MOTOR
 LAC - LOW AMBIENT FAN CONTROL (OPT)
 LASR - LOW AMBIENT SHUNT RELAY (OPT)
 LC - LIMIT CONTROL CUTOFF
 LPS - LOW PRESSURE SWITCH (OPT)
 OFR - OUTDOOR FAN MOTOR
 RVS - REVERSING VALVE SOLENOID

SC - START CAPACITOR (OPT)
 SR - START RELAY (OPT)
 TCB - TELECOM BOARD (OPT)
 TDR - TIME DELAY RELAY (OPT)
 (OPT) - OPTIONAL ACCESSORIES

DRAWING NO. 1120-0011-0000
 REV. F
 BASIC AIR CONDITIONER SYSTEM

DRAWING APPLIES TO
 V34A00A4XXX--XX
 V30A00A4XXX--XX
 V36A00A4XXX--XX
 V42A00A4XXX--XX
 V48B00A4XXX--XX
 V60B00A4XXX--XX

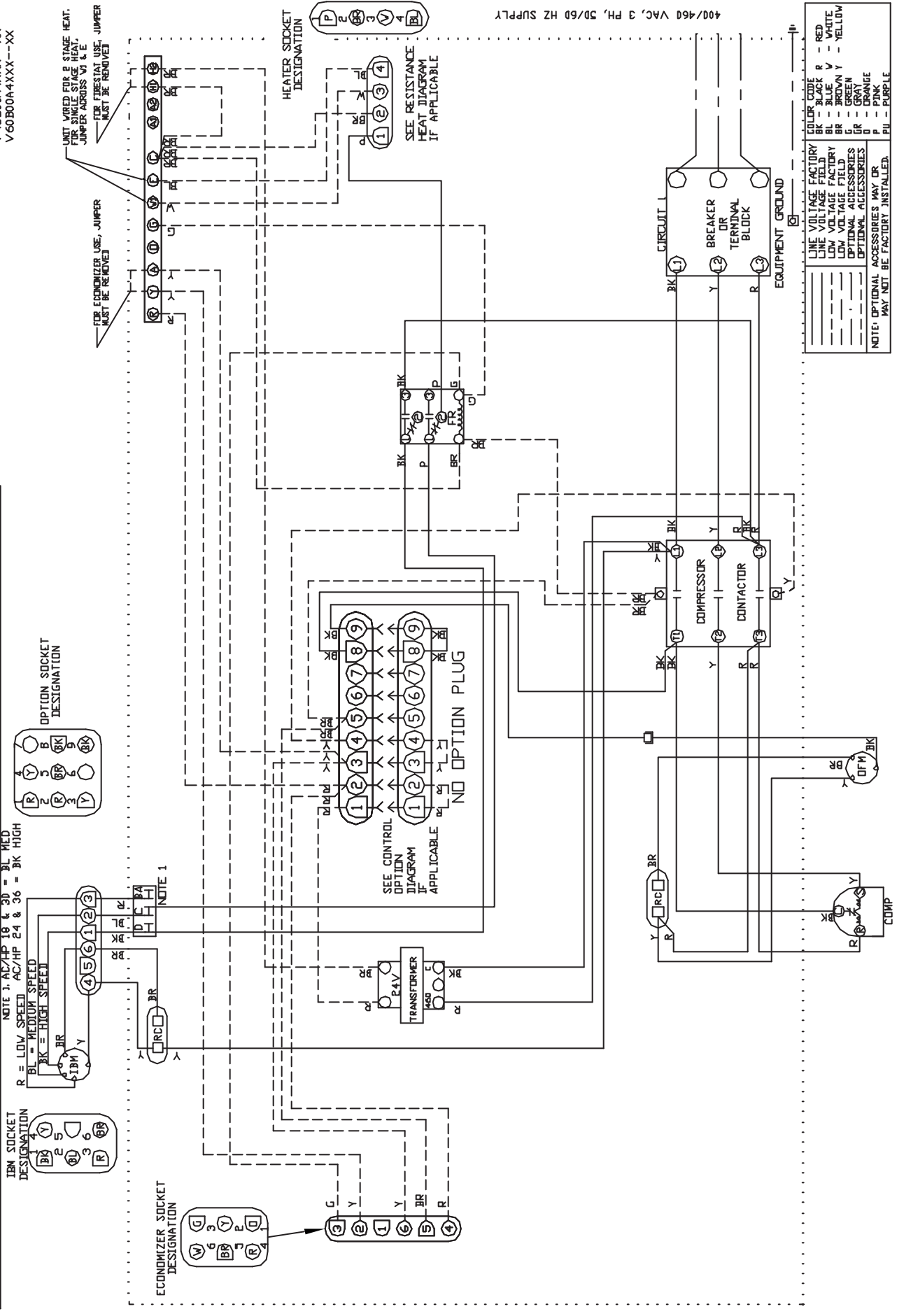

UNIT DIMENSIONS (INCHES)

MODEL	A	B	C	D	E	F	G	H	I	J	K	L	M	N	P	Q	R	S	T	U	V	W	X	Y	Z
V18/24	36	34	18 ⁵ / ₈	28 ¹ / ₁₆	12	20 ¹ / ₂	8	17 ⁷ / ₈	20	28 ⁹ / ₁₆	1 ¹ / ₈	71 ¹ / ₂	2 ¹ / ₂	10 ¹ / ₂	18 ¹ / ₂	26 ¹ / ₂	34 ⁷ / ₈	1 ¹ / ₈	16	32	1 ¹⁵ / ₁₆	2 ⁹ / ₁₆	29 ¹ / ₂	27 ¹ / ₈	27 ⁵ / ₈
V30/36	40	38	18 ⁵ / ₈	28 ¹ / ₂	14	18	8	17 ⁷ / ₈	28	28 ⁹ / ₁₆	1 ¹ / ₈	71 ¹ / ₂	2 ¹ / ₂	10 ¹ / ₂	18 ¹ / ₂	26 ¹ / ₂	39	1 ¹ / ₄	18 ¹ / ₄	36 ³ / ₈	2	2 ⁹ / ₁₆	29 ¹ / ₂	27 ¹ / ₈	31 ⁵ / ₈
V48 V60	43 ¹ / ₈	41	24	27 ¹ / ₂	16	30	10	2 ¹ / ₄	30	36 ¹ / ₂	1 ¹ / ₈	87	2 ¹ / ₂	10 ¹ / ₂	18 ¹ / ₂	26 ¹ / ₂	42	1 ¹ / ₈	19 ³ / ₄	39 ¹ / ₂	6 ¹ / ₂	3 ³ / ₄	29 ¹ / ₂	27 ¹ / ₈	33 ¹ / ₂

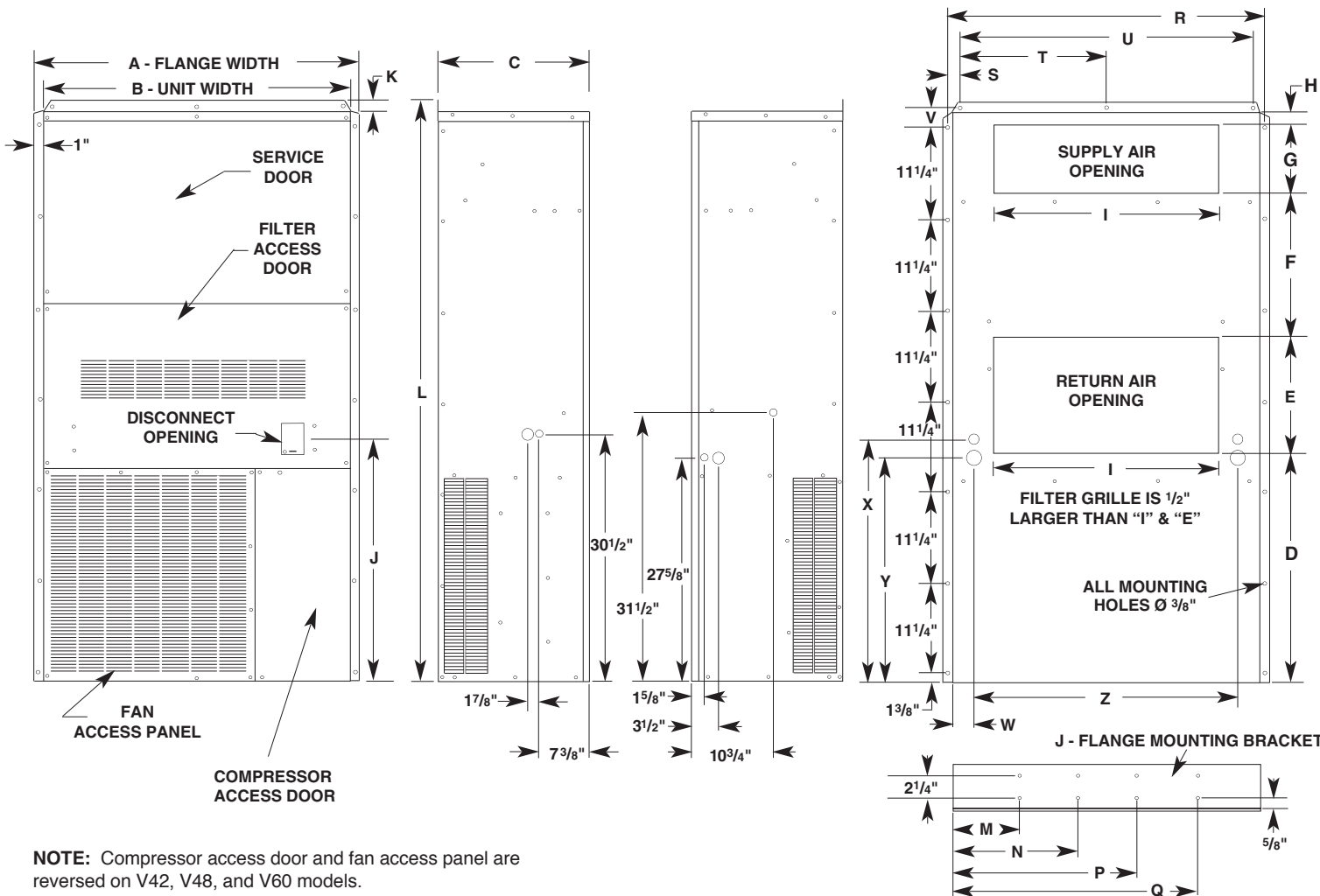

NOTE: Compressor access door and fan access panel are reversed on V42, V48, and V60 models.



The information in this manual supersedes and replaces the previous instruction/operation manual with regards to V Series wallmount products. Illustrations cover the general appearance of the units at the time of publication and the manufacturer reserves the right to make changes in design and construction at any time without notice.

For replacement parts contact:
 National Coil Company
 1998 FM 2011
 Longview, TX 75603
 Phone: 1-903-643-2261